

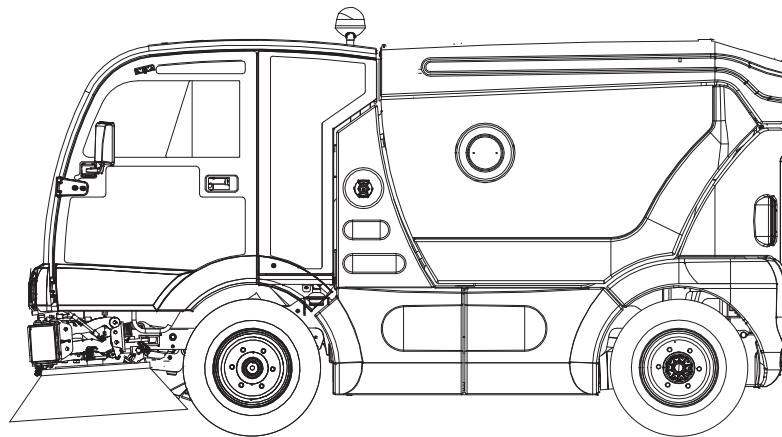

SCARAB SWEEPERS

Technical Specification

Mathieu Azura Concept - Sweeper



The **Mathieu Azura Concept** is one of the most powerful compact road and precinct sweepers, incorporating the latest in technology and design. Powered by a VM Motori 3.0 litre turbo-charged Euro 4 diesel engine with high-pressure direct injection (HDI) it offers reduced exhaust emissions.

The rear wheel hydrostatic drive system gives the vehicle a travel speed of up to 50 kph and a gradeability of 25%. The electronic control optimises the engine power, giving very smooth acceleration/deceleration and variable governed engine speed for sweeping between 0 - 15 kph (9 mph). The sweeping equipment is mounted on a 4500 kg G.V.W. fully sprung chassis for improved ride quality.

The standard vehicle is supplied with a fully equipped cab, versatile variable position brushes and automatically-selected 2 and 4 wheel steering for transit and work modes.

Technical innovation and advanced design make the Mathieu Azura Concept an extremely versatile compact sweeper, capable of undertaking most arduous sweeping tasks.

CAB: The fully appointed rubber mounted and sound insulated custom cab has a host of standard features including cloth covered fully adjustable driver's suspension seat and a foam padded fixed passenger seat, sun visors, laminated windscreen, rear corner visibility windows and sliding side-windows all tinted plus a glazed floor panel to aid suction nozzle visibility. The fully adjustable steering column provides a comfortable driving position with drop down drivers armrest with full brush controls via joystick. The cab comes complete with entry / exit handles and gas-strut assisted driver and passenger doors.

Mirrors – 2 rear facing, 1 offside kerb mirror, 1 nearside kerb mirror

Windscreen Wiper – Single, two speed, self parking with washer

Steering Column – Control lever for selecting Forward / Reverse, Drive / work mode selection. Wiper functions, horn, speedometer, engine tachometer with warning lights for engine warning, engine temperature, brake warning, low fuel level, high beam, direction indicator, battery charge and glow plug. Fuel gauge and engine hour meter and buttons for parking brake and hazard warning lights.

Overhead Console – Gauges for engine temperature, water tank level, ignition switch, door operated interior light, switch panel and indicators for sweeping functions, headlights, low hydraulic oil, high temperature hydraulic oil, hopper raised and engine warning. Console also houses controls for the cab heating and ventilation system.

Other – The cab comes additionally equipped with work hour meter and stereo radio CD player and fire extinguisher,

CHASSIS: The Mathieu Azura Concept chassis has been designed specifically for street cleansing.

Constructed from high tensile steel to withstand the abuse of operation under the most severe conditions, it is fully sprung on front and rear axles. The four 205/75R14 pneumatic tyres give the chassis a low footprint loading when operating on paving slabs and other surfaces. Hydraulic assisted power steering makes for easy operation in confined areas and high ground clearance assists with kerb mounting / dismounting.

FRONT AXLE: Heavy-duty steel steering axle plated at 2250 kg

REAR AXLE: Heavy duty steel axle plated at 2250 kg with direct drive hydraulic motor with automatic selection of rear steering when engaging work mode.

BRAKES: Hydraulic double piston front disc braking. Hydrostatic braking on rear wheel and hydraulic parking brake on rear axle.

WHEELS AND TYRES: 14 inch steel rims with 205/75R14 tyres all round.

ELECTRICAL SYSTEM: Negative earth - 12 volt 95 Ah maintenance-free battery. The VM engine is equipped with a 105 Amp Alternator and a 2.3 kW Starter Motor. The system is fully coded and is protected by an in-cab fuse and relay box. Full Road Lighting, reverse bleeper and demountable rotating cab beacon.

ENGINE: Turbocharged VM Motori 3.0 litre D754 EU4 diesel engine with direct injection (HDI). Meets the latest Euro 4 regulations, ensuring reduced exhaust emissions. Maximum torque is 270 Nm at 1350 rpm and power output is 62 kW at 2300 rpm. Supplied by a 70 litre fuel tank with in-line filter and water separator.

TRANSMISSION: Mathieu's unique hydrostatic transmission comprising hydraulic pumps coupled directly to the engine and powering a hydraulic motor mounted on the rear axle. The drive system has two operating modes and vehicle speed is controlled by a single foot pedal. The system provides smooth acceleration and maximum economy for both driving and work mode. The engine rpm can be adjusted during working to give optimum brush and suction fan drive.

HYDRAULIC SYSTEM: All hydraulic power is supplied by tandem pumps directly connected to the rear of the transmission pump powering the suction fan and brush equipment. All services to the brushes are controlled from the inside the cab. The hydraulic system is protected by filters and a rear mounted oil cooler to ensure long life to all components.

SUCTION FAN: The 650mm diameter suction fan is rubber mounted in the hopper top. Driven by hydraulic motor and giving a nominal air flow of 13,000 cu. m per hour.

SUCTION NOZZLE: 540mm wide and manufactured from 'Creusabro' steel offering exceptional wear resistance it incorporates a semi automatic flap for ingestion of large objects. The nozzle is fitted with a castor wheel and rubber flaps ensuring efficient pick up. The nozzle is connected to the hopper via a class leading 250mm diameter suction tube preventing blockages, whilst water spray jets provide dust suppression

FRONT BRUSHES: Two 900 mm diameter front brushes with direct-drive hydraulic motors. The brushes are mounted on unique variable position arms allowing the brushes to be extended forwards to reach into confined areas or to be trailed offering complete protection from damage. Both brushes have fully adjustable speed and ground pressure. Each brush has dust suppression water spray jets and a work light, to assist operation in low light conditions.

WATER PUMP: A hydraulically driven piston water pump provides the dust suppression system with up to 10 litres per minute @ 10 bar. The system is protected by suction filter and pressure regulator.

HOPPER: Corrosion resistant roto-moulded plastic hopper and hopper cover.. Hydraulic tipping rams provide a 45 deg tipping angle for rapid discharge. Easily cleaned pleated and perforated stainless steel filter screens in hopper top giving a large surface area..

WATER TANK: Two 180 litre corrosion resistant roto-moulded plastic pannier water tanks mounted to the sides of the chassis. Filling points on left and right hand sides of machine.

PAINTING: Vehicle comes with designated panels that can be painted in customer specific RAL code.

SWEEPING PATTERN: Sweeping widths can be varied from 1250mm to 2450mm using the in cab joystick control

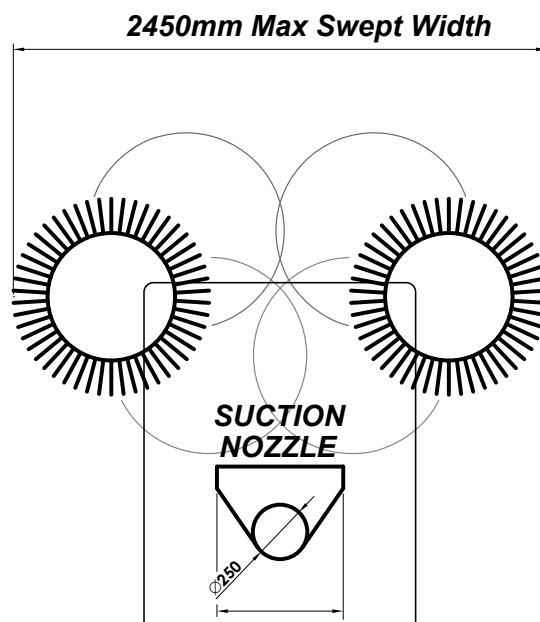

PRINCIPAL DIMENSIONS	
VEHICLE HEIGHT	1980 mm
VEHICLE WIDTH	1250 mm
VEHICLE LENGTH	3900 mm
TYRE TURNING RADIUS	3.6 m (kerb - kerb)
GVW	4500 kg
UNLADEN WEIGHT	2700 kg
FRONT AXLE PLATED WEIGHT	2250 kg
REAR AXLE PLATED WEIGHT	2250 kg
TIPPING HEIGHT	1500mm

OPTIONS:

High-pressure Water Pump. 15 litres per minute @ 200 bar. Trigger operated hand lance and 5 metres of hose. Quick-release connection point under cab.

Wanderhose. 150mm dia flexible wanderhose 2.4m long with 0.9m long rigid entry tube. Connection points on either side of body. Mounted in hinged and removeable carrier frame on rear of vehicle.

Colour CCTV system to rear

In-cab Air Conditioning

Front brush angle adjustment from cab

Additional front mounted mirror

Additional beacon to rear of hopper

Quick release brushes

Spare wheel

Vehicle jack

Other options and operator specific requirements available upon request.

Scarab Sweepers are the sole UK distributor of Mathieu.S.A. products.

Mathieu are dedicated to continuous product development and as such reserve the right to change this specification without prior notice.

To ensure latest information contact the Scarab Sales Department



Pattenden Lane, Marden, Tonbridge, Kent. TN12 9QD
Telephone: 01622 831006
Fax: 01622 832417
E-Mail: scarab@scarab-sales.com
Web Site: www.scarab-sweepers.com