

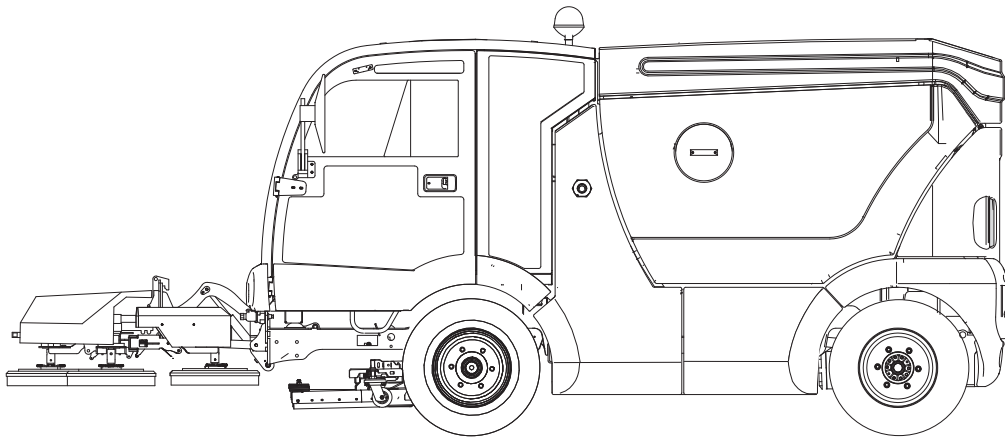

Mathieu Aquazura Concept - Vacuum Scrubber Dryer



The **Mathieu Aquazura Concept Vacuum Scrubber Dryer** is one of the most powerful road and precinct cleaners of its type, incorporating the latest in technology and design. Powered by a VM Motori 3.0 litre turbo-charged Euro 4 diesel engine with high-pressure direct injection (HDI) it offers reduced exhaust emissions.

The rear wheel hydrostatic drive system gives the vehicle a travel speed of up to 50 kph and a gradeability of 25%. The electronic control optimises the engine power, giving very smooth acceleration/deceleration and variable governed engine speed for cleaning between 0 - 15 kph (9 mph). The scrubbing equipment is mounted on a 4500 kg G.V.W. fully sprung chassis for improved ride quality.

The standard vehicle is supplied with a fully equipped cab, and automatically-selected 2 and 4 wheel steering for transit and work modes.

The fully floating five brush scrubbing head with variable ground pressure ensures the best cleaning results on uneven ground and multiple types of surface. The automatic detergent dispenser is capable of carrying a variety of different solutions for a multitude of cleansing needs.

Technical innovation and advanced design make the Mathieu Aquazura Concept Vacuum Scrubber Dryer an extremely versatile compact machine, capable of undertaking most arduous cleaning tasks.

CAB: The fully appointed rubber mounted and sound insulated custom cab has a host of standard features including cloth covered fully adjustable driver's suspension seat and a foam padded fixed passenger seat, sun visors, laminated windscreen, rear corner visibility windows and sliding side-windows all tinted plus a glazed floor panel to aid suction nozzle visibility. The fully adjustable steering column provides a comfortable driving position with drop down drivers armrest with full brush controls via joystick. The cab comes complete with entry / exit handles and gas-strut assisted driver and passenger doors.

Mirrors – 2 rear facing, 1 offside kerb mirror, 1 nearside kerb mirror

Windscreen Wiper – Single, two speed, self parking with washer

Steering Column – Control lever for selecting Forward / Reverse, Drive / work mode selection. Wiper functions, horn, speedometer, engine tachometer with warning lights for engine warning, engine temperature, brake warning, low fuel level, high beam, direction indicator, battery charge and glow plug. Fuel gauge and engine hour meter and buttons for parking brake and hazard warning lights.

Overhead Console – Gauges for engine temperature, water tank level, ignition switch, door operated interior light, switch panel and indicators for work functions, headlights, low hydraulic oil, high temperature hydraulic oil, hopper raised and engine warning. Console also houses controls for the cab heating and ventilation system.

Other – The cab comes additionally equipped with work hour meter and stereo radio CD player and fire extinguisher,

CHASSIS: The Mathieu Azura Concept chassis has been designed specifically for street cleansing.

Constructed from high tensile steel to withstand the abuse of operation under the most severe conditions, it is fully sprung on front and rear axles. The four pneumatic tyres give the chassis a low footprint loading when operating on paving slabs and other surfaces. Hydraulic assisted power steering makes for easy operation in confined areas and high ground clearance assists with kerb mounting / dismantling.

FRONT AXLE: Heavy-duty steel steering axle plated at 2250 kg

REAR AXLE: Heavy duty steel axle plated at 2250 kg with direct drive hydraulic motor with automatic selection of rear steering when engaging work mode.

BRAKES: Hydraulic double piston front disc braking. Hydrostatic braking on rear wheel and hydraulic parking brake on rear axle.

WHEELS AND TYRES: 14 inch steel rims with 205/75R14 tyres all round.

ELECTRICAL SYSTEM: Negative earth - 12 volt 95 Ah maintenance-free battery. The VM engine is equipped with a 105 Amp Alternator and a 2.3 kW Starter Motor. The system is fully coded and is protected by an in-cab fuse and relay box. Full Road Lighting, reverse bleeper and demountable rotating cab beacon.

ENGINE: Turbocharged VM Motori 3.0 litre D754 EU4 diesel engine with direct injection (HDI). Meets the latest Euro 4 regulations, ensuring reduced exhaust emissions. Maximum torque is 270 Nm at 1350 rpm and power output is 62 kW at 2300 rpm. Supplied by a 70 litre fuel tank with in-line filter and water separator.

TRANSMISSION: Mathieu's unique hydrostatic transmission comprising hydraulic pumps coupled directly to the engine and powering a hydraulic motor mounted on the rear axle. The drive system has two operating modes and vehicle speed is controlled by a single foot pedal. The system provides smooth acceleration and maximum economy for both driving and work mode. The engine rpm can be adjusted during working to give optimum brush and suction fan drive.

HYDRAULIC SYSTEM: All hydraulic power is supplied by tandem pumps directly connected to the rear of the transmission pump powering the suction fan and brush equipment. All services to the brushes are controlled from the inside the cab. The hydraulic system is protected by filters and a rear mounted oil cooler to ensure long life to all components.

SUCTION FAN: The 650mm diameter suction fan is rubber mounted in the hopper top. Driven by hydraulic motor and giving a nominal air flow of 13,000 cu. m per hour.

COLLECTION TANK: A roto-moulded corrosion resistant collection tank is capable of discharging at a height of 1500mm at an angle of 45 degrees.

WATER SYSTEM: The 500 litre fresh water capacity allows the Aquazura to work for extended periods. The hydraulically driven water pump can deliver up to 15 litres / minute at 3 bar whilst in-cab valves control flow to the brushes. The in-cab level gauge advises the driver of water remaining whilst an automatic shut-off protects the water pump from running dry.

SCRUBBING ATTACHMENT: The front scrubbing head comprises 5 independently floating brushes with direct drive hydraulic motors ensuring the brushes remain in contact with the ground on uneven surfaces. The unit is capable of applying a variable ground pressure to suit the surface and application. The two outer brushes can be rotated outward from the in-cab joystick to vary the scrubbing width. The standard 'Carborandum' brushes can rapidly be interchanged with alternative material equivalents to provide a machine that can tackle any type of surface cleaning duty.

SQUEEGEE AND SUCTION NOZZLE: The 1600mm wide stainless steel suction squeegee incorporates a central flap for ingestion of larger debris. The castor wheels and rubber flaps ensures the nozzle follows the ground profile giving maximum collection of waste water, leaving the cleaned area virtually dry. The squeegee nozzle is connected to the body via a 200mm diameter suction hose for superior performance.

DETERGENT DISPENSER: A 30 litre capacity detergent tank can carry various detergent types for specific cleaning applications and can deliver a variable dose between 0 and 5% via a venturi injector. Detergent is fed through the center of the brush to ensure a good distribution and maximum efficiency of cleaning.

PAINTING: Vehicle comes with designated panels that can be painted in customer specific RAL code.

SWEEPING PATTERN: Scrubbing widths can be varied from 1230mm to 2100mm using the in cab joystick control

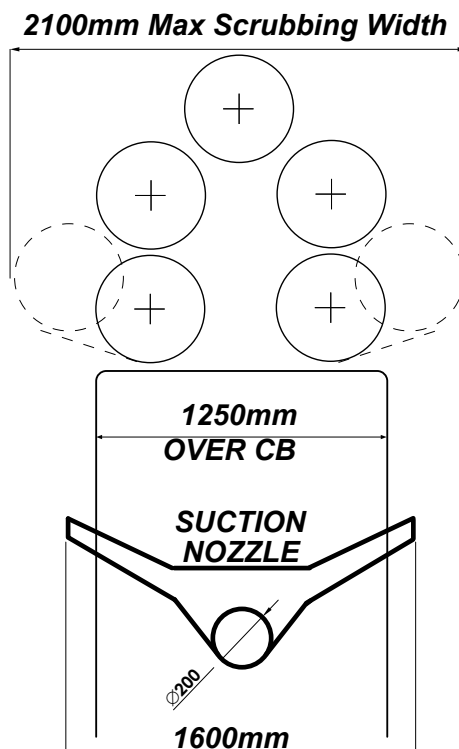

PRINCIPAL DIMENSIONS

| | |
|--------------------------|---|
| VEHICLE HEIGHT | 1980 mm |
| VEHICLE WIDTH | 1250 mm Over Cab 1600 mm Over Squeegee |
| VEHICLE LENGTH | 5050 mm |
| TYRE TURNING RADIUS | 3.6 m (kerb - kerb) |
| GVW | 4500 kg |
| UNLADEN WEIGHT | 2700 kg |
| FRONT AXLE PLATED WEIGHT | 2250 kg |
| REAR AXLE PLATED WEIGHT | 2250 kg |
| TIPPING HEIGHT | 1500mm |

OPTIONS:

Colour CCTV system to rear

In-cab Air Conditioning

Additional beacon to rear of hopper

Spare wheel

Vehicle jack

Other options and operator specific requirements available upon request.

Scarab Sweepers are the sole UK distributor of Mathieu.S.A. products.

Mathieu are dedicated to continuous product development and as such reserve the right to change this specification without prior notice.

To ensure latest information contact the Scarab Sales Department



SCARAB
SWEEPERS

Pattenden Lane, Marden, Tonbridge, Kent. TN12 9QD

Telephone: 01622 831006

Fax: 01622 832417

E-Mail: scarab@scarab-sales.com

Web Site: www.scarab-sweepers.com